



WAU

Seating Products



Sports Design Concept

Wau combines excellent ergonomics to extract human performance and trendy styling to elicit self confidence and satisfaction as you perform.



Recline-Glide Motion

The back and seat pivot axis is placed close to the human's hip socket joint (acetabulum), such that there is no relative movement between the backrest and torso, giving a natural and constant-fit support through the recline range.

Button-less

The backrest, armrest and headrest do not employ buttons or levers, to make adjustments quick and intuitive.



Wau was named after the large traditional Malaysia kite because the curves and shape of the back structure resembles that of the kite's.

Headrest: Adjustable for Height

White or black outer shell and grey inner shell of molded polypropylene (100% recyclable).

Fabric/Leather surface

Upholstered over polyurethane foam (recyclable into carpet padding, wadding etc)

Mesh surface

76% elastomer / 24% polyester high tensile mesh.

Elastomer surfaces

colored SEBS-type thermoplastic elastomer (TPE) overmolding (100% recyclable with PP into flexible, impact-resistant PP product).

Seat: Adjustable for Height

White or black outer shell and grey inner shell of injection-molded polypropylene (100% recyclable).

Base

Five-prong base of diecast aluminum alloy (100% recyclable) in epoxy powder-coating or polished finish. 60mm dual-wheel castors of molded polyamide (nylon).



Backrest: Adjustable for height and lumbar depth.

White or black outer shell, grey inner shell, lumbar knob and caps of polypropylene (100% recyclable). Back frame in white/black fiber-reinforced polypropylene (100% recyclable).

Armrest: Adjustable for height and swivel angle

For Model 608/609 with G62/M62 armrest
Armpad of TPE in grey or orange colour, moulded over a PP shell.

For Model 708/709 with G65 armrest
Armpad of integral PU foam in standard grey colour, moulded over a PP shell.

Armrest upright parts in fiber reinforced polypropylene(100% recyclable) for both type of armrest.

Mechanism: Adjustable Tilt tension and Tilt Lock control

Main structure and backbone of diecast aluminium alloy 100% recyclable. Covers in grey molded polypropylene (100% recyclable). Levers and knob of molded polyamide (nylon). Internal hardware of steel.

Mesh Surface



White 608W MB A00 VG
Black 608B MB A00 VB



White 608W MB G62 VG
Black 608B MB G62 VB



White 609W MB G62 VG
Black 609B MB G62 VB

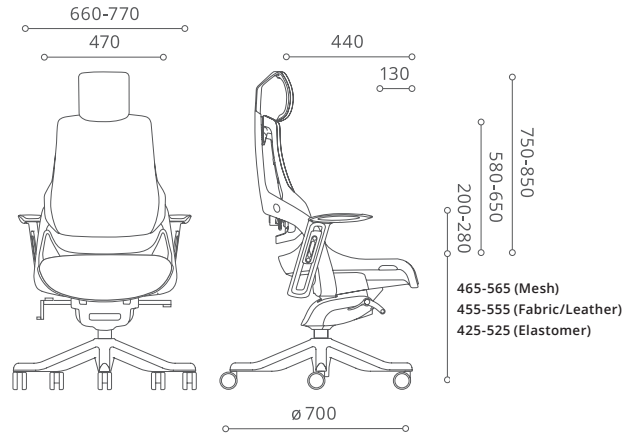

Fabric/ Leather Surface



White 608W MB A00 VG
Black 608B MB A00 VB



White 608W MB G62 VG
Black 608B MB G62 VB



White 609W MB G62 VG
Black 609B MB G62 VB

Elastomer Surface



White 608W MB A00 VG
Black 608B MB A00 VB



White 608W MB M62 VG
Black 608B MB G62 VB



White 609W MB M62 VG
Black 609B MB G62 VB

Mesh Surface



White 708W MB A00 VG
Black 708B MB A00 VB



White 708W MB G65 VG
Black 708B MB G65 VB



White 709W MB G65 VG
Black 709B MB G65 VB

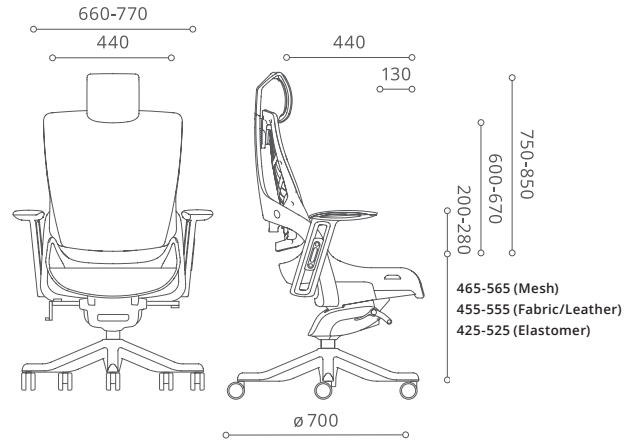

Fabric/ Leather Surface



White 708W MB A00 VG
Black 708B MB A00 VB



White 708W MB G65 VG
Black 708B MB G65 VB



White 709W MB G65 VG
Black 709B MB G65 VB

Elastomer Surface



White 708W MB A00 VG
Black 708B MB A00 VB



White 708W MB G65 VG
Black 708B MB G65 VB



White 709W MB G65 VG
Black 709B MB G65 VB

Wau: Options

2 standard color-ways



Black
(B)



White
(W)

2 standard color for elastomer surface



Mango
(M)



Grey
(G)

Base Options



Polished Aluminium
(VP)



Black Epoxy Aluminium
(VB)



Silver Epoxy Aluminium
(VG)







arma®